

Frühlings Event Baggenstos “HP Networking”

Netzwerk Konvergenz und Total Cost of Ownership

April 2010





ProCurve
Networking

Hans-Peter Dreifuss
Partner Account Manager
HP Networking Schweiz

About HP ProCurve



- Networking Division of the number one IT vendor – part of ESSN:
- The #1 Standard based networking vendor
- The world's #2 campus networking vendor
- Faster growing networking vendor
- Leader in Gartner Magic Quadrant (Campus LAN)

HP to acquire 3Com Corporation



HP to acquire 3Com Corporation

- HP and 3Com signed a definitive agreement on November 11, 2009 for HP to acquire 3Com
- Purchase price of \$7.90 per share in cash, or an enterprise value of approximately \$2.7B
- Expected to close in the first half of calendar 2010

3Com Products

- 3Com Networking Products
- H3C Enterprise Networking Products
- Tipping Point, Intrusion Detection and Prevention

HP ProCurve: Leadership at the edge

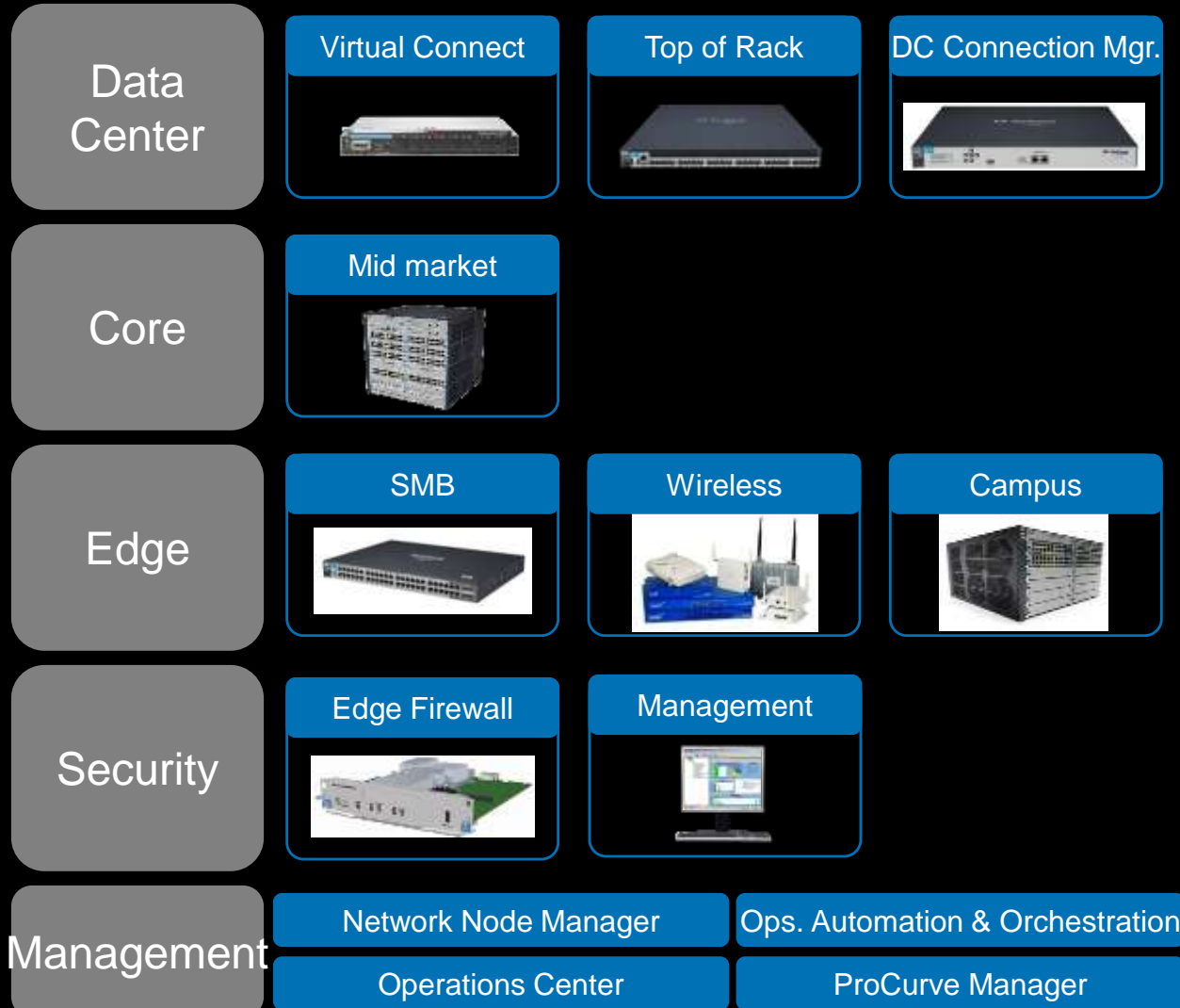

- Successfully integrated Colubris WLAN acquisition
- Launched ProCurve One partnership ecosystem
- Integrated into HP's Enterprise Business, leveraging HP global sales force and Enterprise Services
- Launched UC&C with Microsoft
- Gained momentum in enterprise with numerous marquee wins
- Significantly increased CIO awareness, expected to support momentum

HP + 3Com: Leadership from edge to data center core

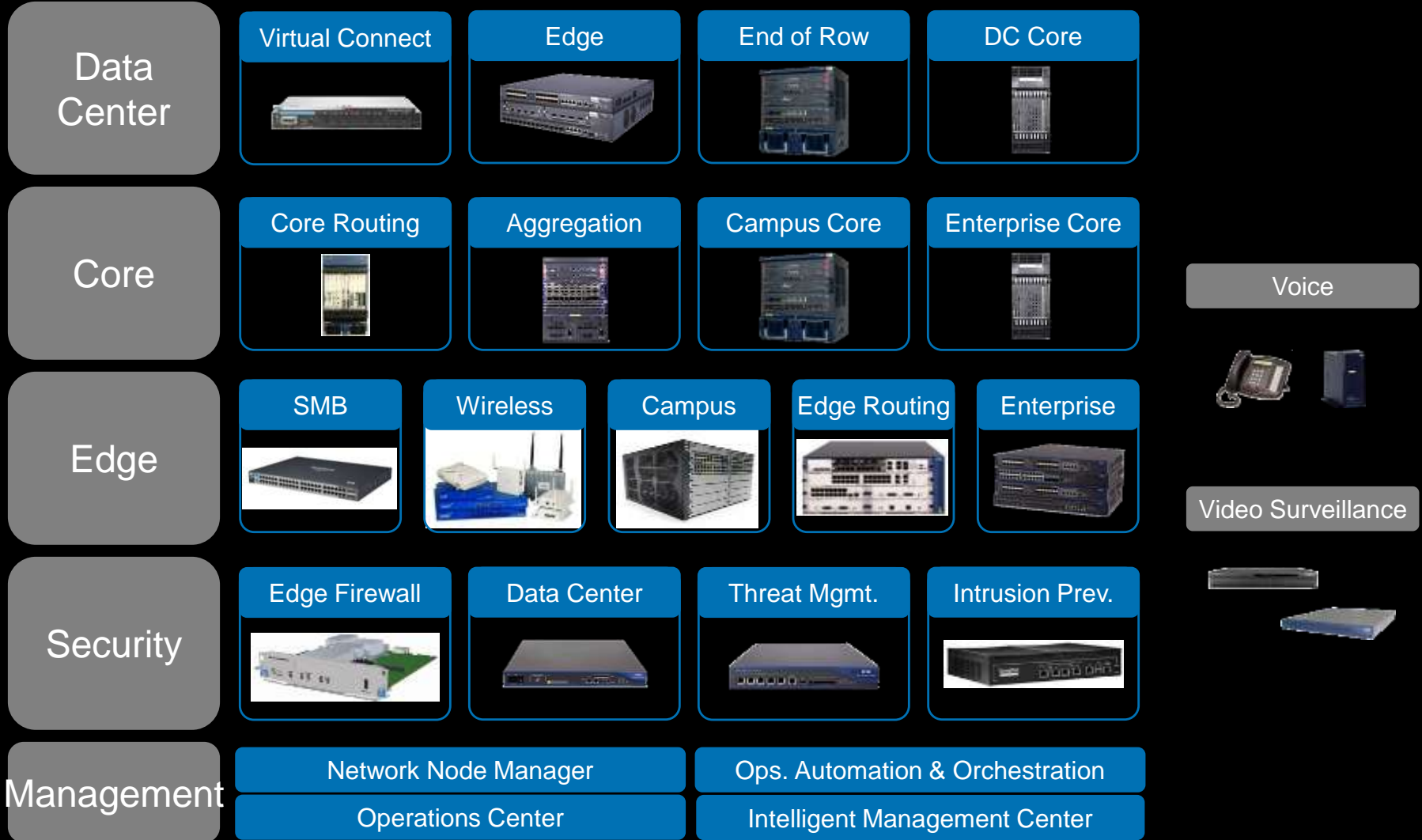

3Com brings strength in high-end data center switching

3Com's Product Leadership Validated by Industry Experts...



"3Com has a product line, when you look at these announcements, that is as broad and robust as anyone out there, including Cisco. I think [Intelligent Management Center] is a unique differentiator. Network management hasn't been the core priority of most network equipment vendors. Even Cisco, with Cisco Works – the development of it tends to be pretty fragmented."

Zeus Kerravala, Yankee Group in TechTarget May 12, 2009 "3Com hopes to win enterprise networking customers with global HC3 push"



"3Com has a completely rejuvenated product offering from workgroup switching and WLAN through to high-capacity core switches."

Gartner Inc., April 30, 2009 "Magic Quadrant for Enterprise LAN (Global)"



"The introduction of H3C products will add a very interesting dimension to the market...3Com now has a range of marquee clients won against top-notch vendors."

Chris Bernard, IDC, May 25, 2009 "3Com Moves Back Into Enterprise Business: Watch This Space"

... And Adopted by Leading Global Enterprises



- Over 300 of the Top 500 Enterprises in China
- The 4th and 5th largest banks in the world
- ~70% of the government networks in China
- The world's 8th busiest airport

Tomorrow's business will be built on a converged infrastructure

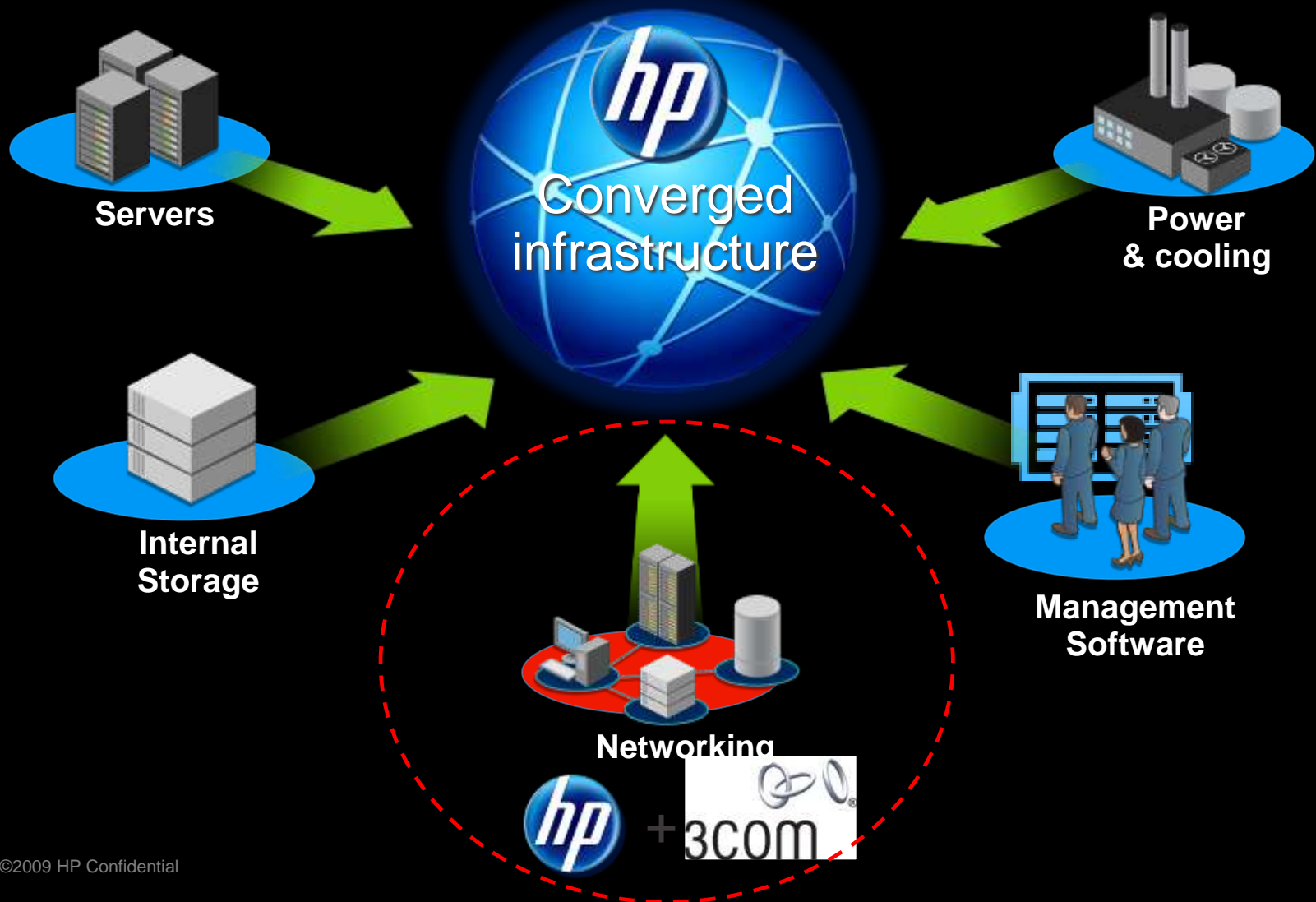

Magic Quadrant: Enterprise LAN (Global), 2009

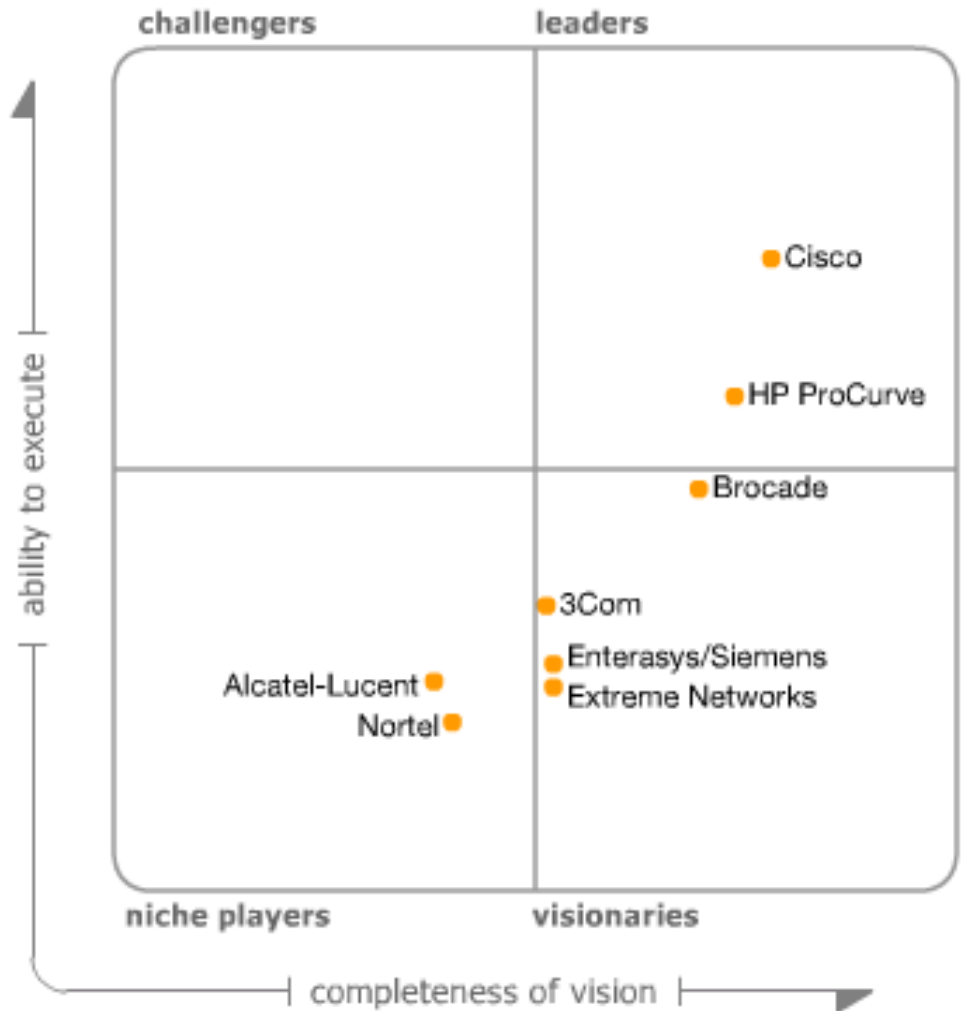

As of April 2009

HP ProCurve positioned in Gartner's Leaders Quadrant

The Gartner Magic Quadrant is copyrighted April 2009 by Gartner, Inc., and is reused with permission. The Magic Quadrant is a graphical representation of a marketplace at and for a specific time period. It depicts Gartner's analysis of how certain vendors measure against criteria for that marketplace, as defined by Gartner. Gartner does not endorse any vendor, product or service depicted in the Magic Quadrant, and does not advise technology users to select only those vendors placed in the "Leaders" quadrant. The Magic Quadrant is intended solely as a research tool, and is not meant to be a specific guide to action. Gartner disclaims all warranties, express or implied, with respect to this research, including any warranties of merchantability or fitness for a particular purpose.

The Magic Quadrant graphic was published by Gartner, Inc., as part of a larger research note and should be evaluated in the context of the entire report. The Gartner report is available upon request from HP ProCurve.

Magic Quadrant for Enterprise LAN (Global), 2009,
Mark Fabbi, Tim Zimmerman,
30 April 2009.

Muster – Pharma LAN RFP & TCO



Übersicht

Muster-Pharma

Der Campus heute...und 2013

HG 3.OG

HG 2.OG

HG 1.OG

HG EG

HG UG

R&D 1.OG

R&D EG

R&D DC

Produktion 1

Produktion 2

HG DC



Netzwerk Design



Layout

Familienansatz

- ProVision Familie sorgt für einheitliche Plattform bezüglich FW, Konfiguration, Management und Austauschbarkeit der Komponenten
- Dieser Vorteil wird verstärkt durch ausschliessliche Verwendung von PoE+ Modulen und Power Supplies
- Dot1x und Webauth für Gäste
- Spezielle HA Features im Corebereich
- Redundanter L3 Core
- Optionales OSPF Routing
- PIM Multicast Routing
- Multiple Spanning Tree



Muster-Pharma

Netzwerk Hauptgebäude

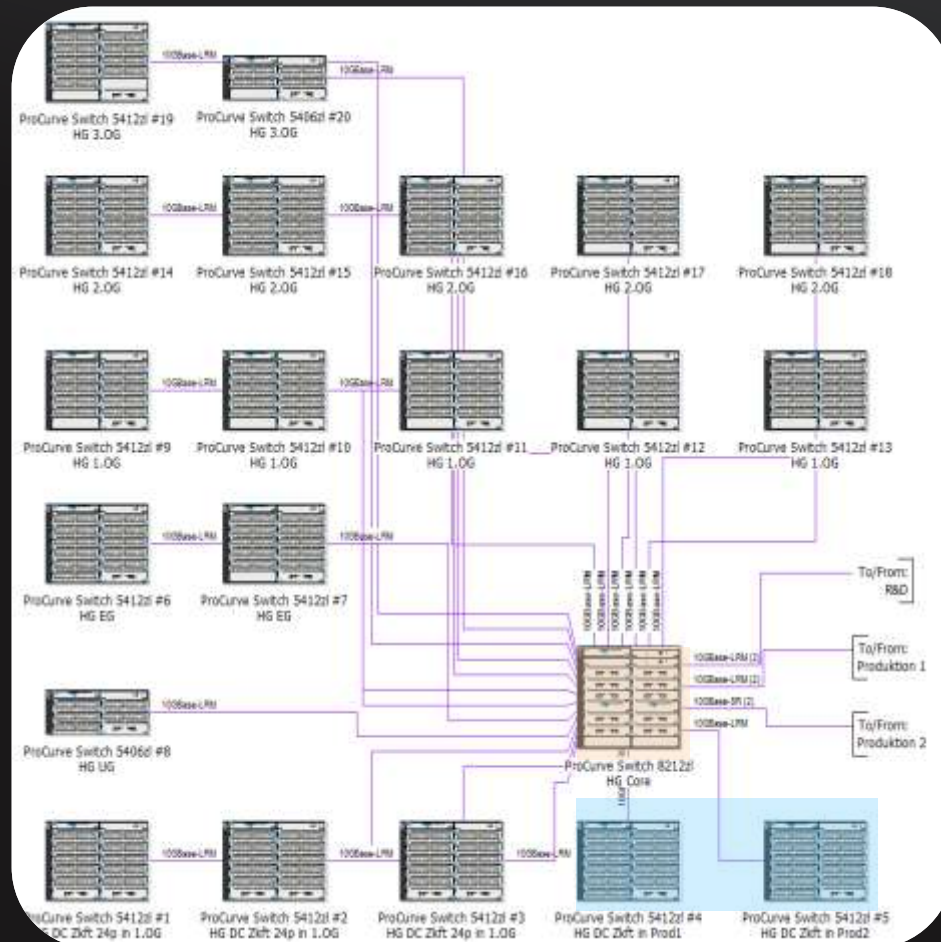

- Primärer **Core Switch**
- **2 DC Switches** können für Produktion genutzt werden
- **24 Port Module** werden im 1.OG weiterverwendet
- DC Switches haben 4 PS für N+N Redundanz, welche später ggf. PoE+ Bedarf abdecken können

Muster-Pharma

Netzwerk R&D

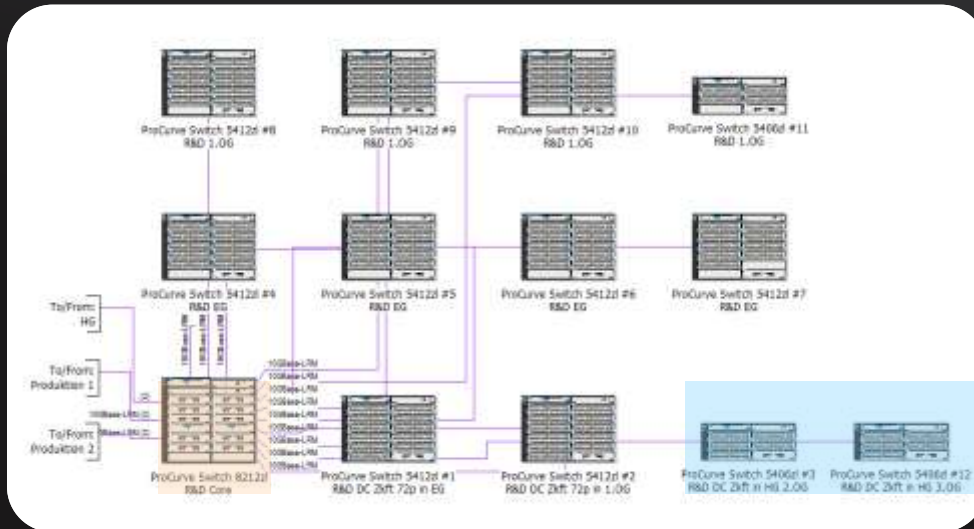

- Sekundärer Core Switch
- 2 DC Switches können für HG Access genutzt werden
- 24 Port Module werden im Access weiterverwendet
- DC Switches haben 4 PS für N+N Redundanz, welche später ggf. PoE+ Bedarf abdecken können

Muster-Pharma

Produktion 1&2

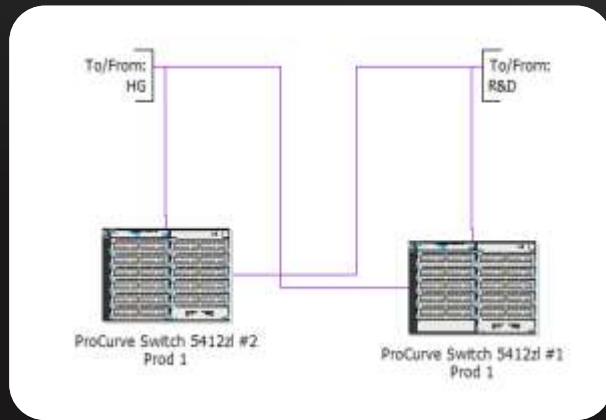

- Verbinden direkt auf Core Switches
- 300m Strecke zwischen Produktion 2 und HG mit SR Modul
- Nehmen HG DC Switches auf

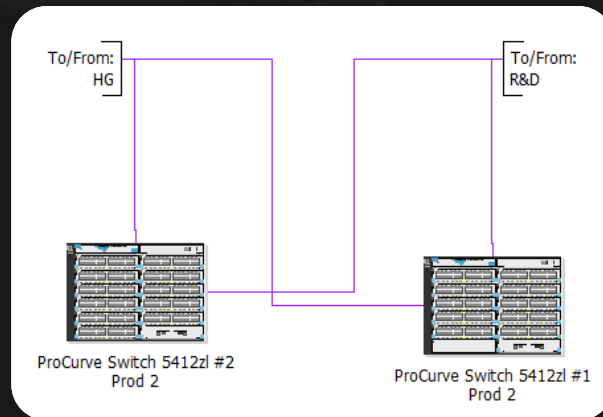

HP ProCurve End of Row Switches

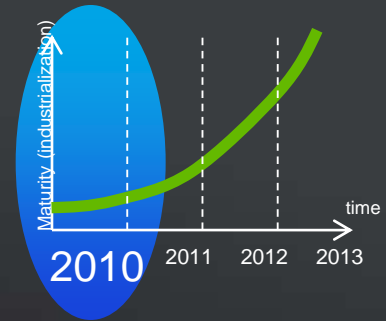

L2/L3/L4 Modular Switches

Modules Available

8212zl



- 24 port 10/100/1000 PoE
- 20 port 10/100/1000 PoE + 4 port GBIC

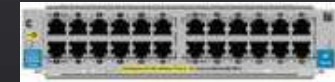

5412zl



- 24 port GBIC
- 4 port X2 10GbE
- 4 port CX4 10GbE
- ONE Module
- Threat Management System (FW/IPS/VPN Gwy)

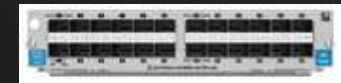

5406zl



Unified Network Management

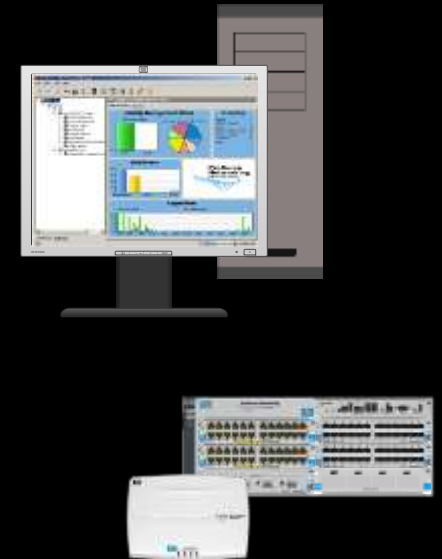
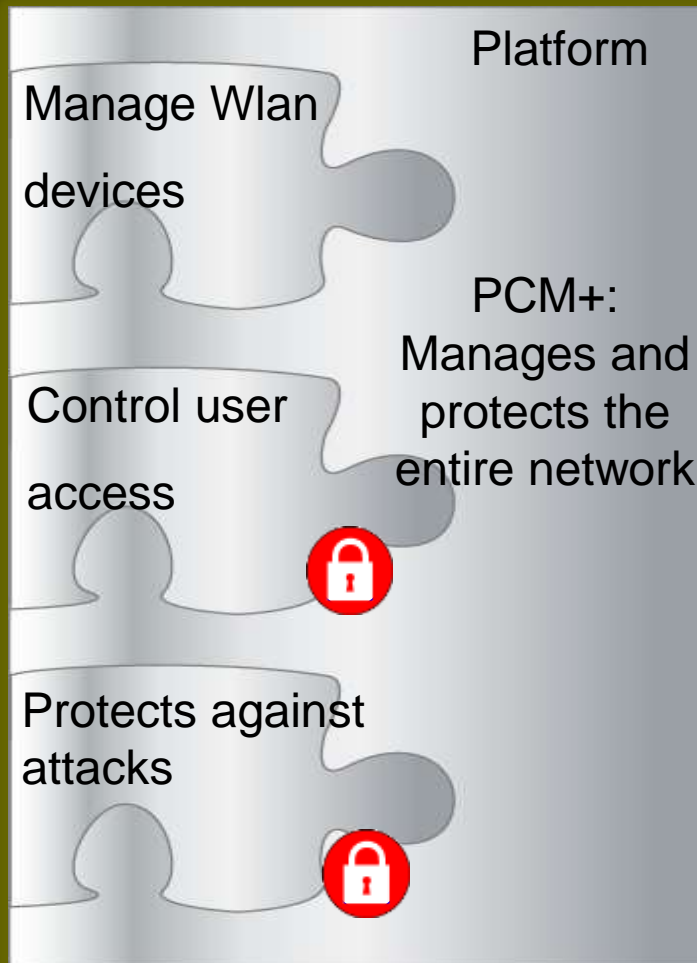
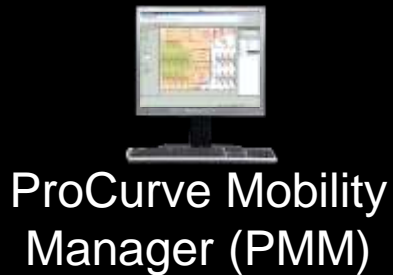

Vorteile HP Loesung



Gezeigte Lösung

- Uneingeschränkte Austauschbarkeit der Module und Netzteile durch einheitliche Produkte (Familienansatz)
- Wiederverwendung der DC Infrastruktur im wachsenden Access Bereich
- Durch flächendeckendes PoE+ ohne Beschränkung auf dedizierte Ports für zukünftige Technologien nutzbar
- Dot1x und Webauth für Gäste steht überall zur Verfügung
- Virus Throttling, sFlow und unsere Management Software vervollständigen den Begriff „Proaktives Netzwerk“ bei geringstem Aufwand



HP ProVision Familie

- ProVision ASIC ist IPv6 ready und kann auch re-programmiert werden
- Remote Port Mirroring über GRE Tunnels erlaubt eine zentralisierte Fehleranalyse
- FW, LB, WLAN Controller, WAN Acceleration, VoIP etc. Funktionalität kann durch ONE Module einfach hinzugefügt werden
- ProVision Familie heisst 1 Firmware Version und 1 Konfigurationssyntax



The logo for ProCurve Lifetime Warranty is a blue oval with a silver border. The text "ProCurve" is in a smaller font at the top, "Lifetime" is in a larger font in the middle, and "Warranty" is in the largest font at the bottom. The text is white with a slight shadow effect.

ProCurve Lifetime Warranty

- Umfassendes Produkt und Management Portfolio
- Number 1 Standard based Networking Vendor, ergibt Möglichkeiten für Multivendor Lösungen
- Vorteilhafte 'Total Cost of Ownership', Preis-Leistungsverhältnis
- HP Support Qualität, Gratis Telefonsupport, Gratis Software Updates, Gratis Web-Support
- Allianzen mit Markführer

Technische Zusammenfassung



Beurteilung von HP durch AtRete

Besonderheiten

- Switched Layer 2 Access und Layer 3 routed Core
- Ein Switchtyp für Access und Datacenter Bereiche (Gleicher Produktreihe)
- Alle Ports mit PoE+ ausgerüstet
- Alle Komponenten unterstützen IPv6

Stärken

- Einfachstes Produktportfolio im Access und Datacenter
- 1 Firmware und 1 Syntax für alle Komponenten
- LifetimeWarranty auf allen Komponenten

Schwächen

- FCoE erst nach Übernahme von 3Com und nicht mit den angebotenen Produkten verfügbar



Finanzielle Betrachtung von AtRete



Investitionskosten im 1. Jahr

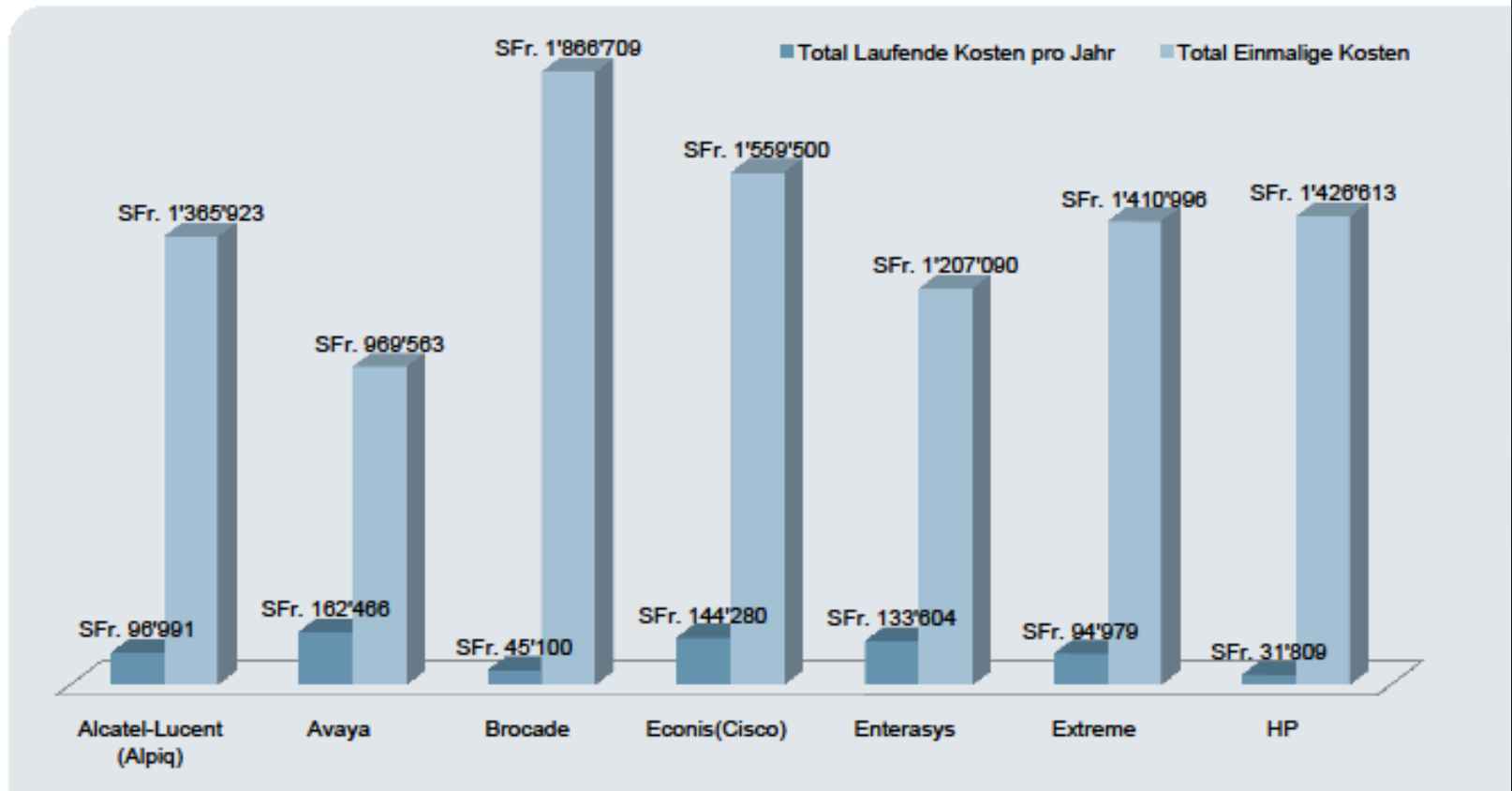

Investitionskosten über 5 Jahre

inkl. HW, SW, Staging, HW Support onsite 4h, Remote 1h (7*10h)

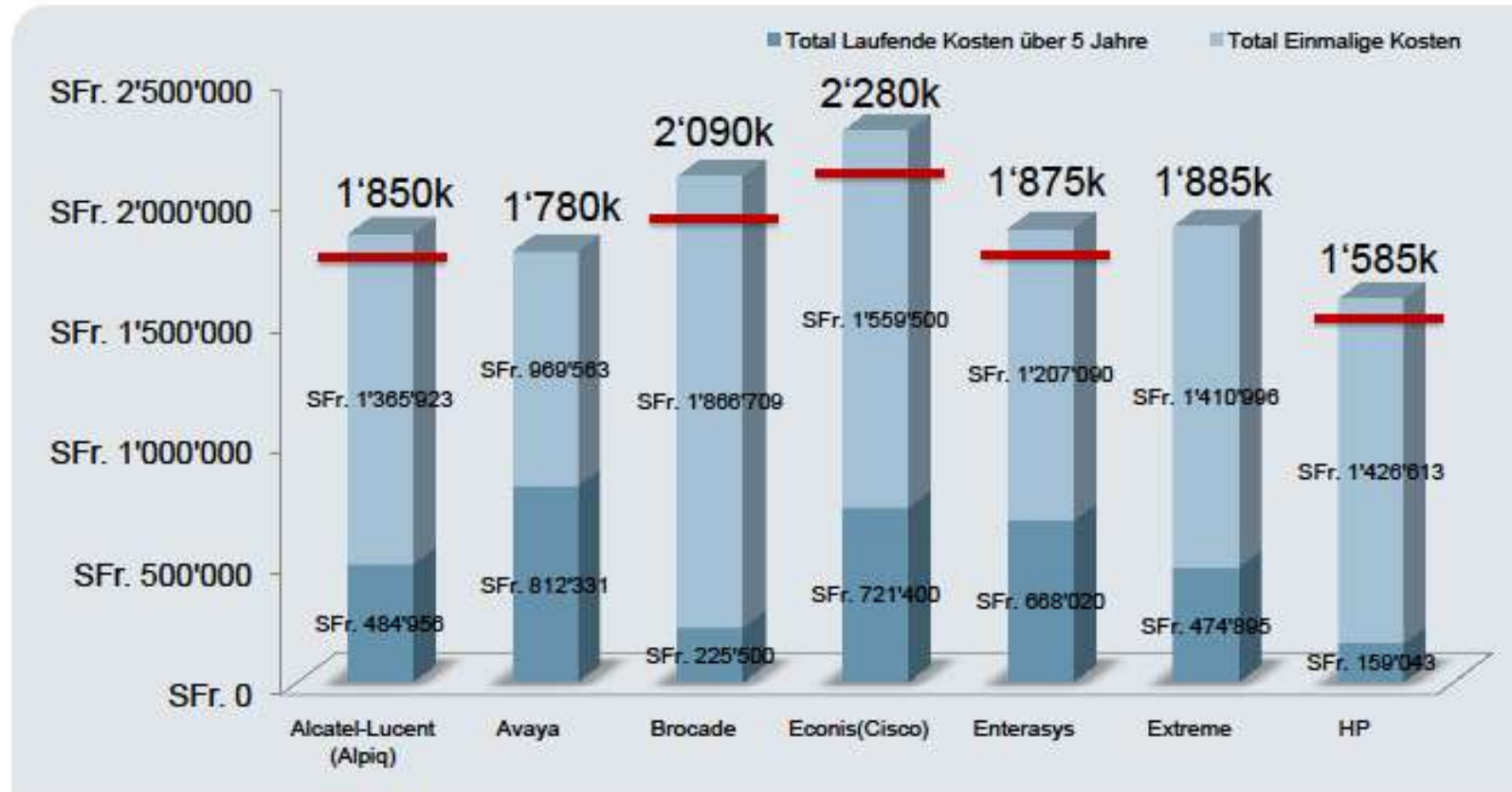

Key Values HP Networking



HP ProCurve product and support highlights.

Number 1 Standard based Networking Vendor,

Positioned in Gartner's Leading Quadrant

Superior Total Cost of Ownership, Price / Performance Leadership

HP Product Quality, Innovative Technologies, Easy, Reliable, Scalable

HP Support Quality, Free phone support, Free Software Updates, Free Web-Support

Alliances with Market Leaders

HP Care Packs and Deployment Services available



Customer References



Customer References

A sample of EMEA customers

International Space Station (EADS)

SAP

The British Library

Hilton Hotels

Four Season's Hotel Florence

STRATO Rechenzentrum AG

Microsoft Technology Center

CERN

BBB-IT School Baden

Privatbank IHAG Zürich

Nidwaldner Kantonalbank

Würth Itensis

PRIVATBANK IHAG ZÜRICH



Q&A

